

Compensator

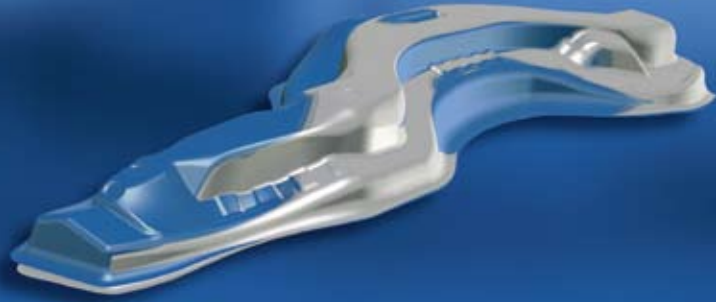
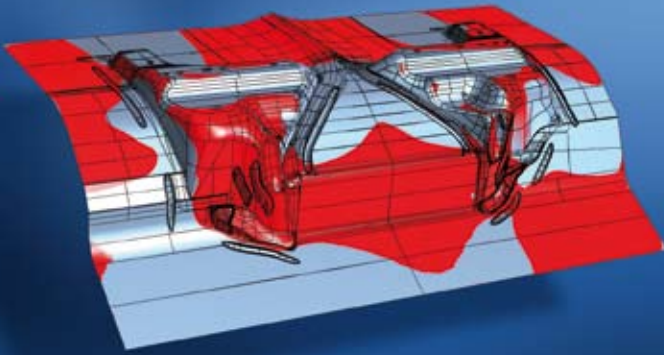

Helping to solve manufacturing problems with a better, faster design process

Compensator was developed from think3's next-generation CAD system, ThinkDesign. Delivering on the promise of "Target-Driven Design," ThinkDesign represents a brand-new approach to design and frees designers from technology constraints. Target-Driven Design technology allows you to assign targets—points, curves, etc. Designers can focus exclusively on product shape, automatically transforming your design into engineering models, preserving design intent for analysis and manufacturing. Evolution of Global Shape Modeling (GSM³) technology, created by think3, ThinkDesign provides engineers and designers with breakthrough creation and modification capabilities: faster iterations and unlimited design creativity, with no rebuilding. Applying GSM³ technology, Compensator was developed to help solve specific manufacturing problems.

Our Customers have Manufacturing Problems to Overcome

Listening to his own customers think3 understand their need to modify surface models, when tooling modifications are required, and solve specific manufacturing problems. Generally, users design a product with all the information needed for the manufacturing process. During the manufacturing process, problems and errors are typically introduced. For example, in the injection molding process the part will shrink and warp as plastic reacts to very hot temperatures and subsequent cooling. Designers try to predict this resulting shrinkage/warping (in plastic parts) behavior. Another example occurs in the automotive industry. Similar material problems, such as "springback," also occur when stamping a sheet metal part, which is usually a complex shape. Designers must attempt to correct or project for those materials problems; hence, the need to "compensate." Currently, designers predict what the shape should look like after shrinkage/warping and springback, by using FEA (Finite Element Analysis) tools. An FEA tool uses a mesh or sampling, a tessellated version of the part shape. Designers have refined the FEA process, allowing them to achieve highly accurate results. However, the FEA process is separate from the design process and requires users to spend large amounts of time and effort integrating the results into the modification of the tooling design.

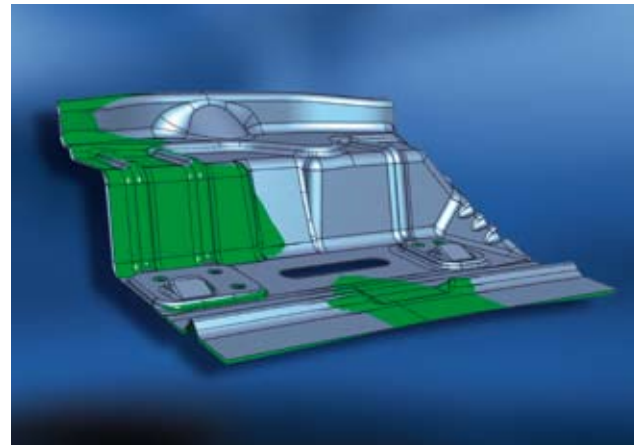

Compensator: the Answer to Compensation Issues

Building on GSM³ technology, think3 developed Compensator to bridge the gap between FEA predictions and optimized tooling design. Compensator automates the process, saving time, replacing tedious manual labor and maintaining the same surface structure (topology) as the original surface model. Using think3 technology with FEA data reduces user interaction, eliminating the need for designers to spend time rebuilding/redrawing compensated surfaces. Compensator speeds the process, allowing designers to create better and/or additional designs and iterations for manufacturing. Initial customer testing suggests an 80% savings in cycle time, when solving and creating intermediate shapes. Materials can be correctly cut the very first time.

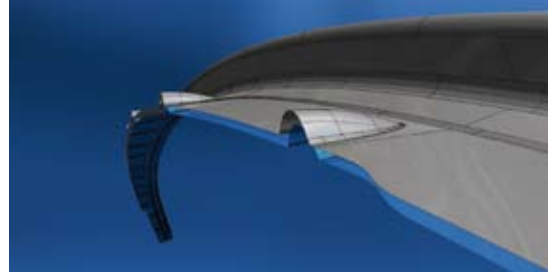

How does it work?

Compensator workflow follows three simple steps:

1. FEM Springback information is read into Compensator
2. Compensator compensate the mesh and export to the FEM to calculate the springback again
3. Compensator load the new loop. If the Springback is equal the target shape TC apply automatically to the surfaces, else we loop again with the FEM until optimized solution.

Outpace the competition

Manufacturing companies today are facing increasing pressures to reduce tooling costs and handle more challenging materials, i.e., high-strength steel. Automating the compensation process, Compensator can help manufacturers outpace the competition.

Mktg 03/2008

System requirements for Compensator Minimum

- Vista™, XP Professional x64 Edition, XP Professional/Home SP2 or higher, Microsoft® Windows® 2000 professional/Server SP4 or higher
- Intel® Pentium 4 2 GHz or equivalent SSE2-enabled processor for AMD systems
- 1 GB System memory (RAM), 1.5 GB for Vista™
- 1 GB Virtual memory (paging)
- 600 MB Hard disk space for a typical installation
- 64 MB OpenGL™ 1.4 Graphics Accelerator
- Microsoft® .NET Framework Version 2.0
- Microsoft® Internet Explorer 6.0 SP1 or higher

Suggested

- Vista™, XP Professional x64 Edition, XP Professional/Home SP2 or higher, Microsoft® Windows® 2000 professional/Server SP4 or higher
- Intel® Pentium 4 2.4 GHz or equivalent SSE2-enabled processor for AMD systems
- 1.5 GB System memory (RAM), 2 GB for Vista™
- 2 GB Virtual memory (paging)
- 600 MB Hard disk space for a typical installation
- 128 MB OpenGL™ 1.4 Graphics Accelerator
- Microsoft® .NET Framework Version 2.0
- Microsoft® Internet Explorer 6.0 SP1 or higher

Supported Special Input devices:

- 3Dconnexion's motion controllers (SpaceBall® 5000, SpaceTraveler™, SpaceMouse®, CadMan®)

think3[®]

www.think3.com

© 2008 think3 Inc. All rights reserved. Think3, the think3 logo, ThinkDesign Styling, ThinkDesign Engineering, ThinkDesign Tooling, ThinkDesign Professional, thinkPLM, thinkteam are registered and unregistered trademarks of think3 Inc. All other trademarks, product names and company names or logos mentioned herein may be the property of their respective owners.